



## VE043LTHAERC

CONVECTION OVEN 4 TRAYS 460 x 340 - GN 2/3\*  
7" SENSITIVE CONTROL  
SELF CLEAN INTEGRATED

### FUNCTIONAL CHARACTERISTICS

|                          |                  |
|--------------------------|------------------|
| Display                  | LCD 2,4" IPS     |
| Supply                   | Electric         |
| Timer                    | -                |
| Number of motors         | 1                |
| Motor speeds             | 5                |
| Max cooking temperature  | 260°C            |
| Core probe               | -                |
| Cooking chamber material | AISI304          |
| Opening door             | Flap door        |
| Chimney                  | 30mm open        |
| Humidification           | Direct injection |
| Air injection            | -                |
| Self-washing             | Standard         |

\*Special tray rack support on request



## STANDARDS

|               |    |
|---------------|----|
| Certification | CE |
|---------------|----|

## TRAYS

|            |  |
|------------|--|
| Trays rack | 4 x PA WIRE 4/80 (460X340)<br>OPT 4x GA-BIV 4/80 GN2/3<br>PA 460X340 |
|------------|--|

|               |     |
|---------------|-----|
| Max tray load | 4kg |
|---------------|-----|

## DIMENSIONS

|                             |                    |
|-----------------------------|--------------------|
| Oven size with handle WxDxH | 600 x 790 x 560 mm |
|-----------------------------|--------------------|

|                                |                    |
|--------------------------------|--------------------|
| Oven size without handle WxDxH | 600 x 750 x 560 mm |
|--------------------------------|--------------------|

|                    |                    |
|--------------------|--------------------|
| Chamber size WxDxH | 495 x 420 x 345 mm |
|--------------------|--------------------|

|             |        |
|-------------|--------|
| Unit weight | 49,2kg |
|-------------|--------|

## PACKAGING

|           |                     |
|-----------|---------------------|
| Packaging | Pallet + carton box |
|-----------|---------------------|

|                      |                    |
|----------------------|--------------------|
| Packaging size WxDxH | 640 x 810 x 733 mm |
|----------------------|--------------------|

|                            |        |
|----------------------------|--------|
| Unit weight with packaging | 57,6kg |
|----------------------------|--------|

|                                 |   |
|---------------------------------|---|
| Crate packaging size (optional) | - |
|---------------------------------|---|

## ELECTRICAL DATA

### HEATERS 3,1kW 50/60Hz

|       |       |
|-------|-------|
| Power | 3,4kW |
|-------|-------|

|           |         |
|-----------|---------|
| Frequency | 50/60Hz |
|-----------|---------|

|              |         |
|--------------|---------|
| Power supply | 230V 1~ |
|--------------|---------|

|          |     |
|----------|-----|
| Amperage | 15A |
|----------|-----|

|                 |       |
|-----------------|-------|
| Power cord req. | 3G1,5 |
|-----------------|-------|

## WATER CONNECTION REQUIREMENTS

|                            |                     |
|----------------------------|---------------------|
| Humidification Water Inlet | 3/4" M Gas threaded |
|----------------------------|---------------------|

|                     |                   |
|---------------------|-------------------|
| Washing Water Inlet | 8mm quick fitting |
|---------------------|-------------------|

|             |      |
|-------------|------|
| Water drain | 30mm |
|-------------|------|

|                    |     |
|--------------------|-----|
| Max water hardness | 5°f |
|--------------------|-----|

|                                    |            |
|------------------------------------|------------|
| Water pressure requirement min-max | 150-200kPa |
|------------------------------------|------------|

## CONSUMPTION

|  |          |
|--|----------|
| Humidification Water with solenoid valve | 0-2,4l/h |
|--|----------|

|                                |   |
|--------------------------------|---|
| Humidification Water with pump | - |
|--------------------------------|---|

|                    |      |
|--------------------|------|
| Rinse Water @2barG | 7,9l |
|--------------------|------|

|                            |       |
|----------------------------|-------|
| Short Washing Water @2barG | 24,9l |
|----------------------------|-------|



|                           |       |
|---------------------------|-------|
| Long Washing Water @2barG | 31,1l |
| Short Washing Detergent * | 70g   |
| Long Washing Detergent *  | 140g  |

### CONNECTIVITY

|           |          |
|-----------|----------|
| USB       | USB 2.0  |
| Bluetooth | -        |
| Wi-Fi     | Standard |
| Cloud     | Standard |

### ACCESSORIES

|                            |  |
|----------------------------|--|
| Oven stand                 | TA6054H60S - TA6054H60X<br>TA6054H80S - TA6054H80X |
| Wheels kit for stand       | R60B   |
| Hood (Air)                 | -  |
| Hood (Water)               | -  |
| Core probe                 | -  |
| Proofer                    | CA6008DH - MH - M0                                 |
| Stacking kit for 2 ovens   | SK52   |
| Smoker                     | SMK02  |
| Blast Chiller              | -  |
| Blast chiller stacking kit | -  |
| Water softner cover        | WS10   |
| Water softner 6800 l       | WS11   |
| Water softner 12000 l      | WS12   |
| Water pressure adapter     | WPA  |
| Water shower kit           | S1   |
| Detergent 6 kg             | DT2  |
| Detergent 10 kg            | DT4  |



◆ Standard   ◇ Optional   - Not available

| TYPE OF COOKINGS        |                             |
|-------------------------|-----------------------------|
| Convection cooking      | 30°C - 260°C / 86°F - 500°F |
| Combi cooking           | 30°C - 230°C / 86°F - 446°F |
| Steaming cooking        | 30°C - 130°C / 86°F - 266°F |
| Static cooking          | -                           |
| Delta T cooking         | -                           |
| Core probe cooking      | -                           |
| Sous vide cooking       | -                           |
| Low temperature cooking | ◆                           |

| DISPLAY AND CONNECTIVITY |                  |
|--------------------------|------------------|
| Type of display          | 2,4" LCD GRAPHIC |
| Multi-language display   | ◆                |
| Unit set F° or C°        | ◆                |
| Venix cloud              | ◆                |
| Wi-fi                    | ◆                |
| Ethernet port            | -                |
| Web server               | ◆                |
| Usb port                 | ◆                |

| SETTINGS             |           |
|----------------------|-----------|
| Infinity time set    | ◆         |
| Chimney set          | OPEN      |
| Fan speed set        | 5         |
| Dehumidification set | -         |
| Humidity set         | 0-100%    |
| Preheat set          | AUTOMATIC |

| RECIPE COOKING                |     |
|-------------------------------|-----|
| User recipes book             | 100 |
| Factory recipes book          | -   |
| Cooking cycles                | 6   |
| Recipes with name and picture | ◆   |
| Fast recipe selection buttons | 12  |

| SPECIAL CYCLE           |   |
|-------------------------|---|
| Multi-level mix ALL IN  | - |
| Multi-level mix ALL OUT | - |
| Food regeneration       | - |
| Overnight cooking       | ◆ |
| Overnight self clean    | ◇ |
| Cook & hold             | - |



|                                  |   |
|----------------------------------|---|
| Multi-timer                      | ◆ |
| Routine program                  | - |
| Proofing                         | ◆ |
| Fast Cooling                     | ◆ |
| Automatic washing system / Rinse | ◇ |
| Fast start                       | - |
| Recipe scheduling                | ◆ |
| Holding / Mass production        | ◆ |

#### TECHNICAL FEATURES

|                                     |                 |
|-------------------------------------|-----------------|
| Cooking chamber material            | AISI304         |
| Second core probe                   | -               |
| Insertion of the trays              | HORIZONTALLY    |
| Fast loading Pro                    | -               |
| Glass door                          | DOUBLE          |
| Easy clean internal glass           | ◆               |
| High performance thermal insulation | YES             |
| Break drop nebulizer                | -               |
| Lightning                           | LED ON THE DOOR |
| Direct injection humidification     | ◆               |
| Boiler humidification               | -               |
| Opening door                        | NOT REVERSIBLE  |
| Reversing fan                       | ◆               |
| Heavy duty reversing fan            | ◆               |
| Phase cut speed control             | ◆               |
| Inverter speed control              | -               |



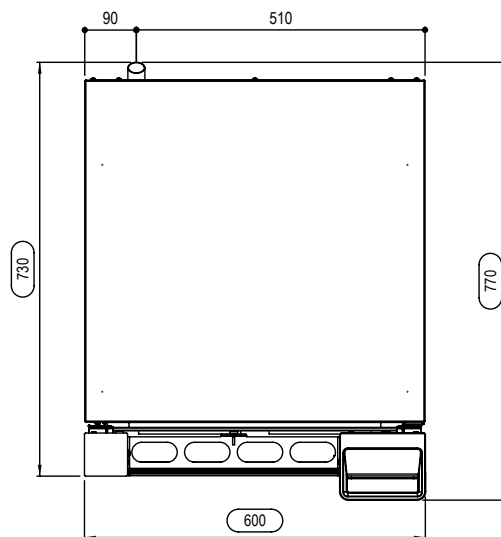
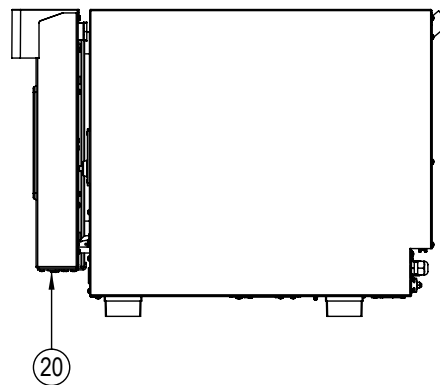
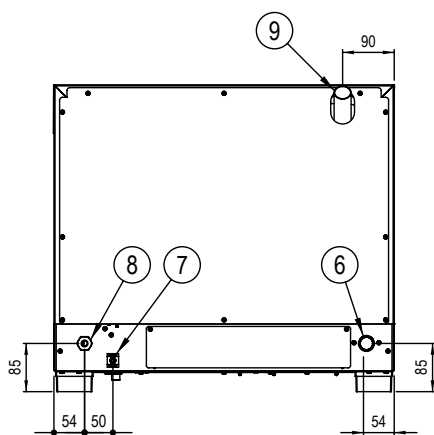
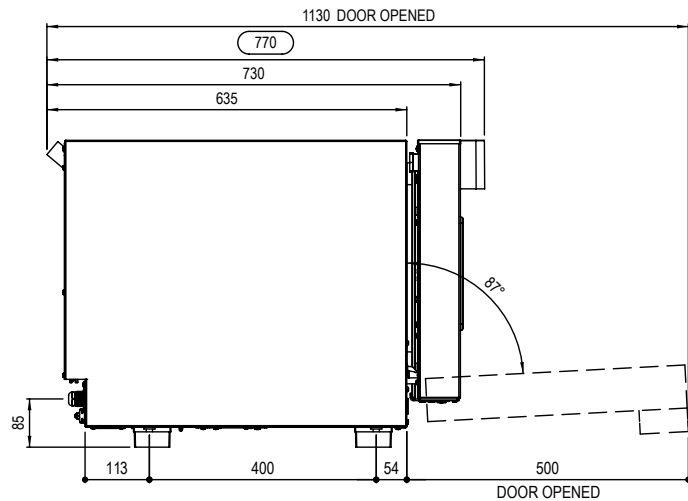
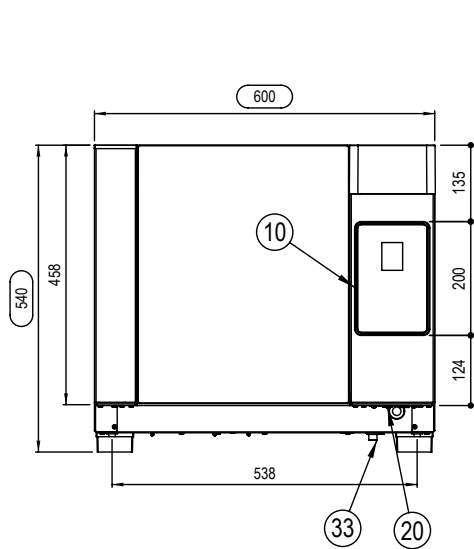

|     |  |
|-----|--|
| 06. | HUMIDIFICATION SOLENOID VALVE 3/4" BSP (GAS) |
| 07. | GROUND TERMINAL                              |
| 08. | COMPRESSION CABLE GLAND                      |

|     |                                 |
|-----|---------------------------------|
| 09. | HOT FUMES EXHAUST CHIMNEY Ø20MM |
| 10. | 2,4" DIGITAL CONTROL            |
| 20. | USB PORT                        |
| 33. | SECURITY THERMOSTAT             |

