

A dynamic, high-speed photograph of a blue water splash, with a large, curved wave of water on the left and a long, thin stream of water extending across the bottom. The water is captured with fine detail, showing ripples and bubbles. The background is a gradient of light blue to white.

Introducing **CleanTech[®] EVO**

A vertical blue bar on the left side of the slide features a dynamic splash of water with bubbles, extending from the top to the bottom.

Product Overview

Meritech's Automated Hygiene Equipment

CleanTech[®] EVO

Outside of the appearance & aesthetics, this latest evolution of CleanTech[®] handwashing stations uses intuitive sensors; state-of-the-art solution cartridges and a full-color touchscreen display to help create the perfect handwashing experience that is:



Effective

Clinically proven to remove more than 99.9% of harmful pathogens with each 12-second hand wash.



Easy to Use

Standardizes hygiene making training, compliance monitoring and documentation effortless across production zones and facilities.



Eco-Friendly

Cuts handwashing time in half using less water than traditional methods while maximizing energy efficiency.

CleanTech® | Product Lines

CleanTech® EVO

Wall



One



Three



In-Counter



Wall Mount

Free-Standing

High-Throughput

In-Counter

CleanTech® Classic



Classic 500 EZ



Classic 2000S



Classic 4000S



Classic ELF-C

EVO Wall

CleanTech® EVO Wall

Wall-Mounted Automated Handwashing System

TECHNOLOGY FOR
HAND HYGIENE



The EVO Wall is our wall-mounted CleanTech® Automated Handwashing Station. This durable system features a watertight cabinet designed for wall mount in high-use areas in both industrial production and commercial environments. Deep cylinders provide effective handwashing beyond wrists to forearms to quickly remove more than 99.9% of pathogens in just 12 seconds.

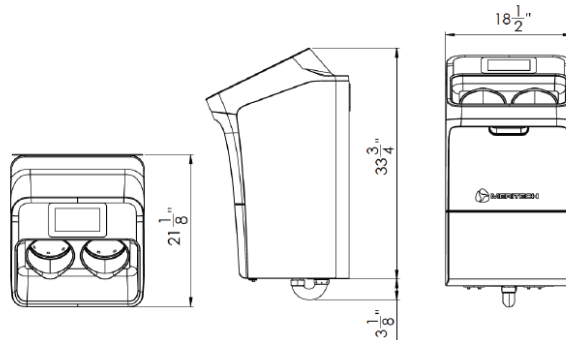

EVO One

CleanTech® EVO One

Single Station Freestanding Automated Handwashing System

TECHNOLOGY FOR
HAND HYGIENE



The EVO One is our CleanTech® Automated Handwashing System with a single station for hand washing. This durable free-standing system features a watertight cabinet designed for high-use areas in both industrial production and commercial environments. Deep cylinders provide effective handwashing beyond wrists to forearms to quickly remove more than 99.9% of pathogens in just 12 seconds.

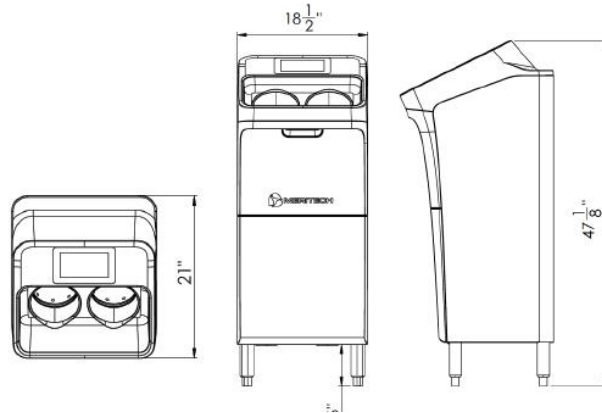

EVO Three

CleanTech® EVO Three

Triple Station Freestanding Automated Handwashing System

TECHNOLOGY FOR
HAND HYGIENE



The EVO Three is our CleanTech® Automated Handwashing System with three stations for hand washing. This durable free-standing system features a watertight cabinet designed for high-use areas in industrial production environments. Deep cylinders provide effective handwashing beyond wrists to forearms to quickly remove more than 99.9% of pathogens in just 12 seconds.

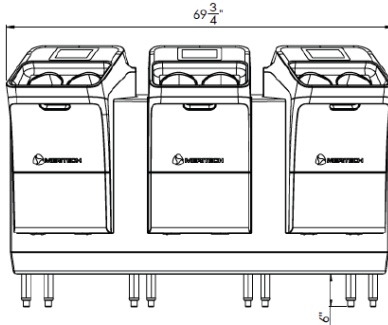

EVO In-Counter

CleanTech® EVO In-Counter

Automated Handwashing System for in-counter installation

TECHNOLOGY FOR
HAND HYGIENE

The EVO In-Counter is a single station CleanTech® Automated Handwashing System designed to install into any counter surface. This durable system features a watertight cabinet designed for high-use areas in industrial production environments. Deep cylinders provide effective handwashing beyond wrists to forearms to quickly remove more than 99.9% of pathogens in just 12 seconds.



(Shown with optional cabinet)

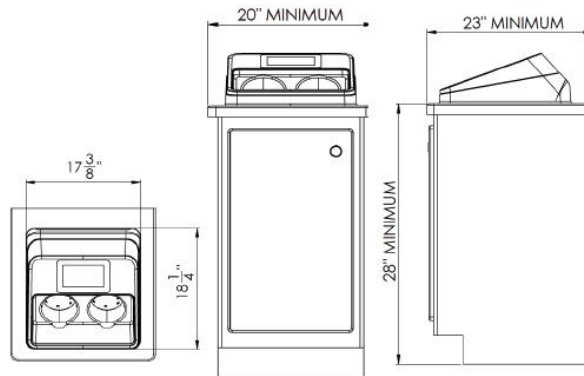

A vertical blue bar on the left side of the slide features a dynamic water splash at the top and numerous small, light-blue bubbles rising from the bottom. The rest of the slide background is a solid, light blue color.

CleanTech® EVO Features

Breaking down the new features of the CleanTech® EVO Systems

CleanTech® EVO Features

The EVO line has four core areas of features that were updated:

- ❑ Plumbing and Utilities
- ❑ User Interface and Customer Engagement
- ❑ Aesthetics and Appearance
- ❑ Concentrated Solutions and Smart Cartridges



Plumbing & Utilities

Updated Plumbing Features

- Compatible with a wide range of facility utilities, with easily identified, universal water inlets for effortless installation
- Internal pressure regulation protects the system and ensures proper water flow for pathogen removal
- Internal backflow prevention satisfies municipality code and regional requirements

Smart Sensors – Compliance and Handwashing Experience

- Pressure sensors monitor facility water pressure and handwash pressure to ensure optimal hand washing experience
- Always an enjoyable handwashing experience with precise temperature control and auto warmup
- Temperature sensors monitor facility water temperature to ensure optimal hand washing experience

Smart Sensors – Maintenance and Safety Features

- System dashboard displays sensor outputs to easily monitor system performance
- Over temperature sensors shutdown system to prevent burning in case of malfunction

User Interface & Customer Engagement

Easy to Use Digital Display Interface

- Colored touchscreen display with easy-to-use interface and customizable display options
- Display that encourages hand hygiene compliance with countdown timer and hygiene tips and training videos (corporate – can be customized for facilities).

Internet-enhanced smart capabilities

- Wi-Fi and Ethernet capabilities allow for proactive communications with internal maintenance teams and Meritech customer support technicians
- Bluetooth-connected app allows for on-the-go compliance tracking and easy diagnostics
- Effortless installation thanks to step-by-step instructions with videos on interactive display

Password-protected admin compliance dashboard

- Password protected admin dashboard allows for easy adjustment of temperature and other operational features
- Hygiene event tracking broken down by day and time with resettable counter for enhanced compliance tracking across shifts

Appearance & Aesthetics

Durable design that's built to last in any hygiene zone

- Sealed chassis constructed of durable plastic and stainless-steel materials that are long lasting in the most demanding environments
- Maintenance is easier than ever with minimal crevasses for easy cleaning and a CIP friendly NEMA 4X water resistant electronics housing

Designed to be ergonomic and safe for all users

- Ergonomic design that is suitable for users of all heights and ages
- Reduced slip hazards thanks to a deep basin that reduces water splashing

Easily installs into any hygiene zone design

- Sleek design that can be configured to fit your hygiene zone - flush wall-mount and free-standing systems or two three-station systems that are back-to-back like a wash fountain
- Install in minutes with easy to reach utility hookups and minimal plumbing requirements

Hygiene Solutions | Product Lines and Messaging

New EVO systems can ONLY use our solutions in our smart cartridges

Added microchip technology allows us to track solution usage and batches for QA/QC

Increased number of hygiene events (2000 per cartridge) that is lighter (5 lbs.) more compact for easier storage and reduced shipping costs



While designed for our systems, these could easily be swapped with cheaper chemicals

No smart technology, a lot of manual tracking needed to determine solution usage and if customer is out of solutions

Weights 24 lbs. and produces 1750 hygiene events. (Price of freight is currently a barrier to entry for a lot of accounts)

“Cartridges”	<u>VS</u>	“Bottles”
--------------	-----------	-----------



Importance of Using Meritech Hygiene Solutions

Our hand hygiene solution has been specifically formulated over 35 years to work with our **Automated Hygiene Equipment** to:

- **Protect employee skin health**
Healthy skin is a critical aspect of hand hygiene. UltraPure has no fragrances or dyes and added moisturizers to promote healthy skin.
- **Ensure the integrity of your Automated Hygiene Equipment**
Meritech equipment has been specifically designed to work with our hygiene solutions. Soap and chemicals other than our hygiene solutions can clog the nozzles and damage the system, voiding its warranty.
- **Guarantee more than 99.9% pathogen removal**
We have performed over [50 independent clinical studies](#) using UltraPure and CleanTech together against a variety of pathogens.

For footwear sanitation, including [automated boot scrubbers](#), your hygiene solution is just as important! Our hygiene solutions ensure the integrity of your system and guarantee pathogen removal.

Self-Clean feature/solution is an optional “add-on” for international customers to help reduce the cost of solution/freight.



EVO Messaging | Core Value Props & Features



CleanTech® EVO supports corporate sustainability initiatives and helps improve efficiency at your organization

- Cartridges can be sent back to Meritech to be recycled/reused, reducing landfill waste.
- Solution cartridges have a fail-proof design for easy installation, saving time and ensuring no solution is wasted.

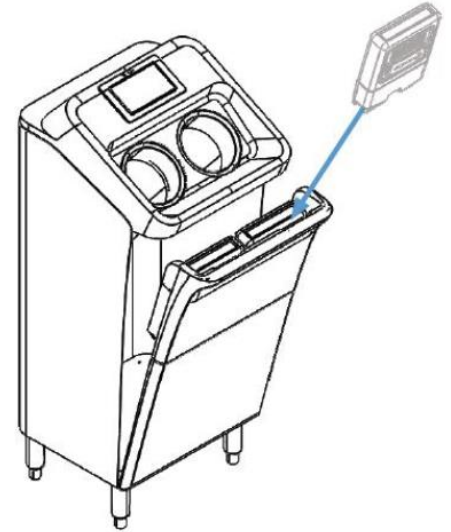

EVO Messaging | Core Value Props & Features



CleanTech® EVO provides peace of mind that all employees have clean hands (and footwear with enhancements)

- World's only automated handwashing station clinically proven to remove more than 99.9% of pathogens with each handwash ([with our hygiene solutions](#))
- Revolutionary handwashing technology with 2 cylinders that have 40 nozzles that rotate around the hands 23 times in 12 seconds to whisk away pathogens ([how CleanTech works video on our website](#))
- Intuitive sensors ensure a comfortable water temperature helping to ensure hand hygiene compliance ([this blog on water temperature and compliance](#))
- No touch points or cross-contamination between users thanks to a photo-eye sensor and closed-loop drainage system
- Recognized as an alternative to traditional sinks by governmental and 3rd party regulatory agencies. ([compliance packet](#))

EVO Messaging | Core Value Props & Features



CleanTech® EVO standardizes hand hygiene and makes developing hygiene SOPs and training new hires on hygiene effortless

- Ensures consistency in hygiene events for each user across shifts, production zones and facility locations ([food safety toolbox](#) and [S.A.V.E. blogs](#))
- Helps to standardize hygiene and build a food safety culture across an organization ([blogs & webinars on food safety culture](#))
- New touchscreen display makes hand hygiene training with new hires effortless with onboarding and training videos and links to the ([Digital Owner's Guide](#))
- Countdown timer helps to encourage compliance with 12-second hand wash cycle and educates users with hygiene tips while they're washing their hands
- Admin dashboard tracks hand hygiene events across various times to help track team compliance and the system will shut down without solution to ensure that there is always a proper hygiene event taking place.